

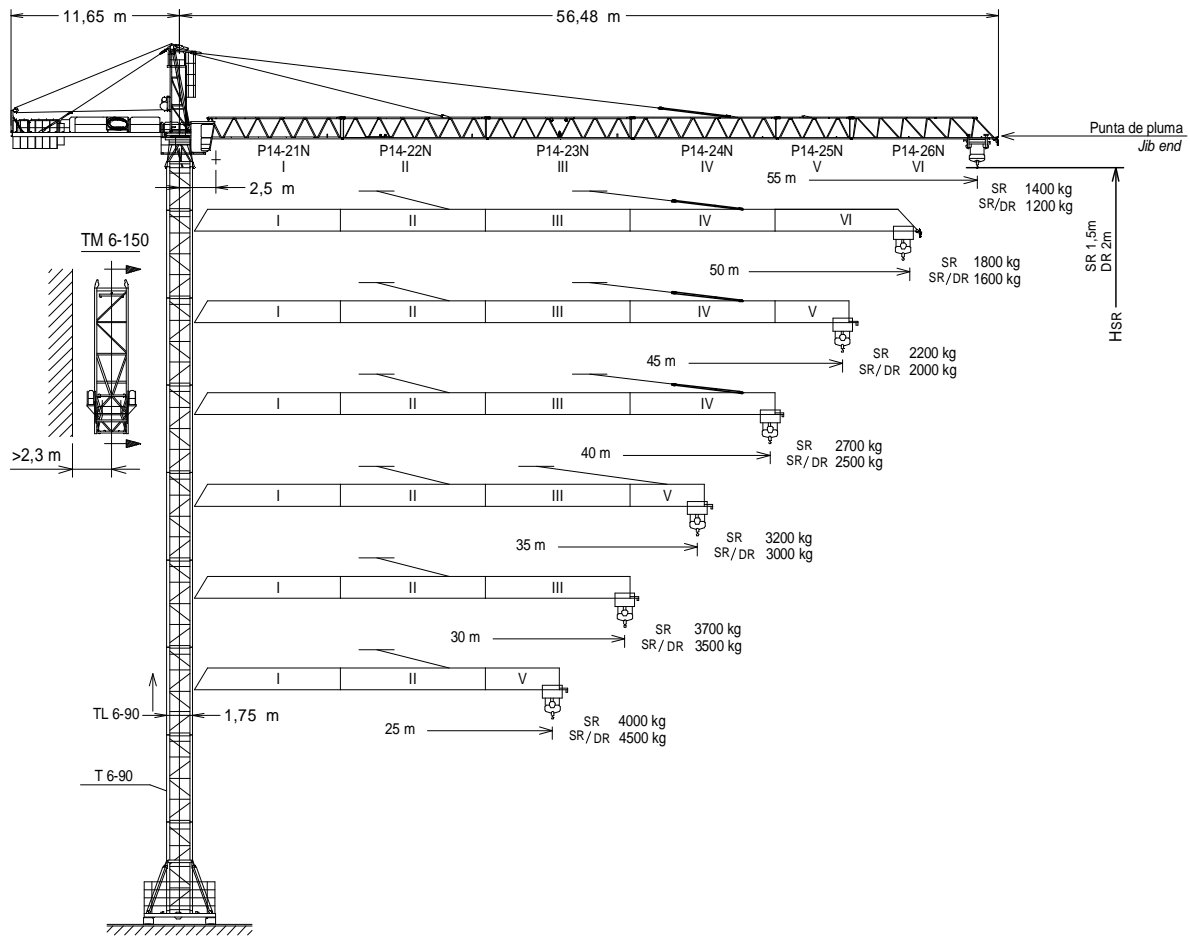

UNE 58-101
FEM 1001

UNE-EN-ISO 9001



$H_{DR} = H_{SR-0,5}$

Altura máxima bajo gancho sin arriostrar (m).
 Maximum height under hook without fastening (m).
 Hauteur maximale sous crochet sans ancrage (m).

$H_{SR} =$ Максимальная высота под крюком без крепления (m).
 Bağılantısız maksimum kanca altı yüksekliği (m).
 أقصى ارتفاع تحت الخطاف بدون ربط (m)

* Punta de pluma / Jib end / Pointe de flèche / Конец стрелы / Вот усу / مقدمة الذراع

TM 6-150	161.35.700	BNI 45-100	145.20.500
T 3-90	133.32.000	BNI 6-150	161.20.000
TL 3-90	158.32.000	ABH 100	201.23.000
T 6-90	133.31.000	P14-21N	158.40.000
TL 6-90	158.31.000	P14-22N	158.41.000
T 6-150	161.31.000	P14-23N	158.42.000
T 6-150A	161.31.300	P14-24N	158.43.000
AN 90	133.21.000	P14-25N	158.44.000
AN 150	161.21.000	P14-26N	158.45.500
		Punta de pluma / Jib end*	158.46.000

(H) TRASLACIÓN / TRAVELLING /

TRASLATION / ПЕРЕМЕЩЕНИЕ / RAY YÜRÜYÜŞLÜ / متحركة

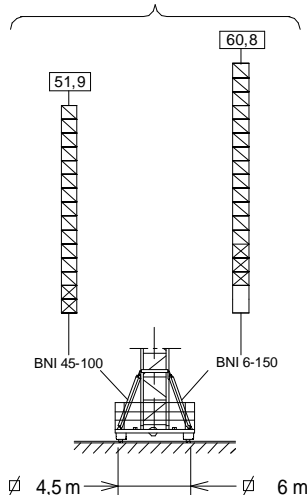

(H) ESTACIONARIA / STATIONARY /

STATIONAIRE / СТАЦИОНАРНОЕ СОСТОЯНИЕ / SABIT / ثابتة

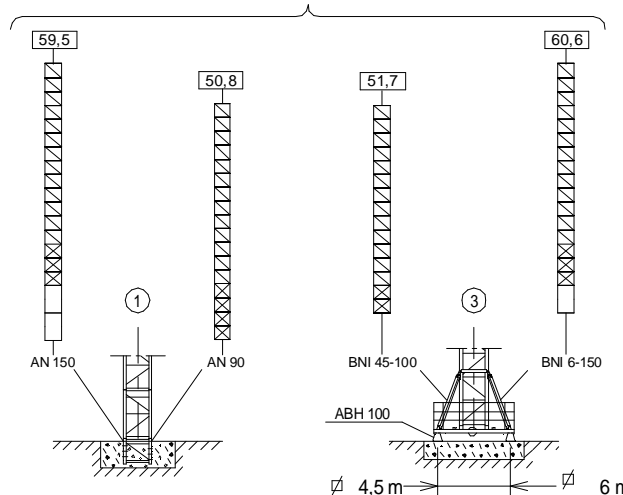

- T 3-90
- TL 3-90
- T 6-90
- TD 6-90
- TL 6-90
- T6-150A
- T6-150
- TD6-150



Fecha / Date: 20/01/2016





Reservado el derecho a modificaciones sin previo aviso. Declinamos toda responsabilidad derivada de la información proporcionada / Subject to modification, without previous warning. This information is supplied without liability / L'entreprise se réserve le droit de procéder à des modifications sans préavis. Nous déclinons toute responsabilité quant aux informations fournies / Мы оставляем за собой право на внесение изменений без предварительного уведомления. Мы снимаем с себя любую ответственность в отношении предоставленной информации / Önceden bildirilmeksizin değiştirilme hakkı saklıdır. Verilen bilgiler için hiçbir sorumluluk kabul etmemekteyiz / حقوق التغيير محفوظة دون إشعار مسبق. دون أدنى مسؤولية عن المعلومات المقدمة





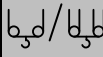







CARGAS / LOADS / CHARGES / НАГРУЗКИ / YÜKLER / الأحمال **J85**

 SR (kg)		Cargas máximas / Maximum loads / Charges maximales / Максимальные нагрузки / Maksimum yük / أقصى حمولة SR1-3.000 kg SR2-4.000 kg							
 [m]	3000-4000 kg @ ... (m)	Alcance del gancho [m] / Hook reach [m] / Portée du crochet (m) / Радиус действия крюка (m) / Kancanın yüksekliği (m) / مدى الخطاف							
		25	30	35	40	45	50	55	
55 m	29,12-22,5	3000-3560	2900	2430	2075	1800	1580	1400	
50 m	32,35-25,0	3000-4000	3000-3265	2745	2350	2045	1800		
45 m	34,41-26,59	3000-4000	3000-3500	2945	2525	2200			
40 m	36,47-28,18	3000-4000	3000-3735	3000-3145	2700				
35 m	35,0-28,64	3000-4000	3000-3800	3000-3200					
30 m	30,0-27,95	3000-4000	3000-3700						
25 m	25,0	3000-4000							

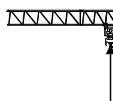
 SR / DR (kg)		Cargas máximas / Maximum loads / Charges maximales / Максимальные нагрузки / Maksimum yük / أقصى حمولة SR1 / DR1 - 3.000 / 6000 kg								
 [m]	3000 / 6000 kg @ ... (m)	Alcance del gancho [m] / Hook reach [m] / Portée du crochet (m) / Радиус действия крюка (m) / Kancanın yüksekliği (m) / مدى الخطاف								
		15	20	25	30	35	40	45	50	55
55 m	27,5 / 15,0	3000 / 6000	3000 / 4350	3000 / 3360	2700	2230	1875	1600	1380	1200
50 m	30,56 / 16,67	3000 / 6000	3000 / 4900	3000 / 3800	3000 / 3065	2540	2150	1845	1600	
45 m	32,5 / 17,75	3000 / 6000	3000 / 5250	3000 / 4080	3000 / 3300	2745	2325	2000		
40 m	34,44 / 18,79	3000 / 6000	3000 / 5600	3000 / 4360	3000 / 3535	2945	2500			
35 m	35,0 / 19,09	3000 / 6000	3000 / 5700	3000 / 4440	3000 / 3600	3000				
30 m	30,0 / 18,64	3000 / 6000	3000 / 5550	3000 / 4320	3000 / 3500					
25 m	25,0 / 19,32	3000 / 6000	3000 / 5775	3000 / 4500						

CARACTERISTICAS DE MECANISMOS / MECHANISMS FEATURES / CARACTÉRISTIQUES DES MÉCANISMES / ХАРАКТЕРИСТИКИ МЕХАНИЗМОВ / MEKANİZMALARIN ÖZELLİKLERİ / الخصائص الآلية **J85**

*opcional *optional *en option *опция *opsiyonel *اختياري								
	EC2556 SR1 18,4 kW	* EC3380VF SR1 24,2 kW	EC2544 SR2 18,4 kW	* EC3360VF SR2 24,2 kW	TG1125VF 2x4 kW	OG1108VF 2x4 kW	TC465VF 3 kW	TH1210 9,2 kW
 m/min	1,5 3 3 56 28 7	1,5 3 0...80 0...40	2 4 4 44 22 5,5	2 4 0...60 0...30	0...25 m/min	0...0,8 r/min / sl/min	0...15 15...32 32...65 m/min	1 m/min
 m/min	3 6 6 28 14 4	3 6 0...40 0...20						
 H	H ≤ SR 240 m DR 120 m		SR 272m		 P _{TOTAL} (EC25XX + OG1108VF + TC465VF) = 29,4 kW P _{TOTAL} (*EC33XXVF + OG1108VF + TC465VF) = *35,2 kW 400V 50Hz			
					 EC2556 EC2544 TH1210 kW +20% m/min +20%			



Fecha / Date: 20/01/2016



Reservado el derecho a modificaciones sin previo aviso. Declinamos toda responsabilidad derivada de la información proporcionada / Subject to modification, without previous warning. This information is supplied without liability / L'entreprise se réserve le droit de procéder à des modifications sans préavis. Nous déclinons toute responsabilité quant aux informations fournies / Мы оставляем за собой право на внесение изменений без предварительного уведомления. Мы снимаем с себя любую ответственность в отношении предоставленной информации / Onceden bildirimeksizin değiştirme hakkı saklıdır. Verilen bilgiler için hiçbir sorumluluk kabul etmemekteyiz / حقوق التغيير محفوظة دون إشعار مسبق. دون أدنى مسؤولية عن المعلومات المقدمة

 **FEM 1001**

LISTA DE EMBARQUE / PACKING LIST /

LISTE DE COLISAGE / СПИСОК ПОСТАВКИ / ÇEKİ LİSTESİ / قائمة التحميل

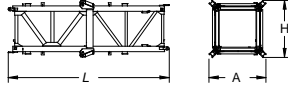
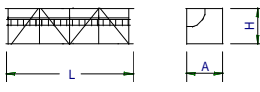
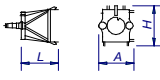
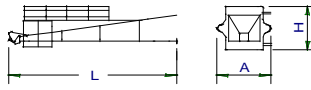
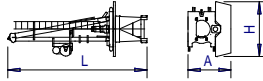
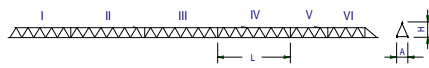
J85

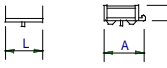
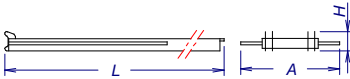
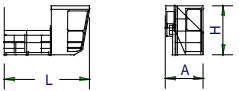
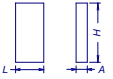
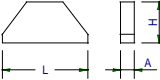
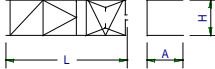
DENOMINACIÓN / DENOMINATION / DÉSIGNATION / НАЗВАНИЕ / AÇIKLAMA / اسم		L [m]	A [m]	H [m]	P / W [kg]
Torre inferior / Lower tower / Tour inférieure Нижняя башня / Alt kule / البرج السفلي	T16-90 T16-150				2500 3535
Torre Tower Tour Башня Kule برج	T3-90 TL3-90 T6-90 TL6-90 T6-150 T6-150A				1200 960 2250 1785 2760 2760
Torre asiento pista + base punta de torre + orientación Slewing table + tower head base + slewing mechanism Tour pivot + base du porte-flèche + mécanisme d'orientation Сиденье площадки + основание верхней секции башни + поворотный механизм Göbek +kule kafa bölümü tabanı+mekanizma برج وحدة الدوارن + قاعدة رأس البرج + آلية الدوران					3400
Punta de torre / Tower head / Porte-flèche верхняя секция башни / kulenin kafa bölümü / رأس البرج					1210
Conjunto asiento pista, punta de torre, orientación y elevación Slewing table assembly, tower head, slewing and hoisting mechanism Groupe pivot + porte-flèche + mécanisme d'orientation + de levage Сиденье площадки + верхняя секция башни + поворотный механизм + подъемный механизм Göbek +kulenin kafa bölümü+mekanizma+vinç kulesi مجموعة وحدة الدوارن + رأس البرج + آلية الدوران + آلية الرفع					5660
Trama de pluma Jib section Tronçon de flèche Секция стрелы Vom bölümü أجزاء الذراع	P14-21N (I) P14-22N (II) P14-23N (III) P14-24N (IV) P14-25N (V) P14-26N (VI)				965 945 785 655 345 530
Polipasto / Hook assembly / Palan / Полуснаст / Kanca takımı / بكرة	SR DR				190 293
Carro / Trolley / Chariot / Грузовая тележка / Şaryo / عربة	SR DR				195 295
Contrapluma con plataformas / Counterjib with platforms Contre-flèche avec plateformes / Противовесная консоль с платформами / Platformlu kuçruk / الذراع المقابل مع المنصة					1575
Plataforma y cabina / Platform and cabin / Plateforme et cabine Платформа и кабина / Platform ve kabin / منصة وكابينة					1280
Contrapeso / Counterweight / Contrepoids / Противовес / Denge ağırlığı / اوزان معاكسة / Grande / Big / Grand / Большой / Büyük / كبير Pequeño / Small / Petit / Малый / Küçük / صغير					2360 1500
Lastre / Ballast / Lest / Балласт / Alt ağırlık taşları / ثقل					6000
Estructura torre de montaje / Jacking cage structure / Structure de tour de montage / Структура монтажной башни / Kaldırma kafesi yapısı / هيكل برج التركيب	TM 6-150				3500

LASTRES INFERIORES / LOWER BALLASTS / LESTS INFÉRIEURS / НИЖНИЙ БАЛЛАСТ / ALT AĞIRLIK TAŞLARI / ثقل J85

BNI 45-100	H (m)	19,4	31,2	40,1	46	51,9
	P (t)	36	48	60	72	84
BNI 6-150	H (m)	28	37	45,8	54,7	60,8
	P (t)	36	48	60	72	96

H: Altura bajo gancho / Height under hook / Hauteur maximale sous crochet Высота под крюком / Kanca alti yüksekliği / الارتفاع أسفل الخطاف

Para alturas intermedias tomar el lastre correspondiente a la altura superior / For intermediate heights take the ballast corresponding to the higher height / Pour les hauteurs intermédiaires, opter pour le lest correspondant à la hauteur immédiatement supérieure / Для промежуточных высот возьмите балласт, соответствующий большей высоте / Orta yükseklikler için daha üst bir yüksekliği kullanınız. / لارتفاعات البينية يرجى استخدام الثقل العائد للارتفاع الأعلى / For intermediate heights take the ballast corresponding to the higher height / Orta yükseklikler için daha üst bir yüksekliği kullanınız.

karşılık gelen ağırlığı alınız. / دون أدنى مسؤولية عن المعلومات المقدمة

Fecha / Date: 20/01/2016

 **FEM 1001**



Reservado el derecho a modificaciones sin previo aviso. Declinamos toda responsabilidad derivada de la información proporcionada / Subject to modification, without previous warning. This information is supplied without liability / L'entreprise se réserve le droit de procéder à des modifications sans préavis. Nous déclinons toute responsabilité quant aux informations fournies / Мы оставляем за собой право на внесение изменений без предварительного уведомления. Мы снимаем с себя любую ответственность в отношении предоставленной информации / Önceden bildirilmeksizin değiştirilme hakkı saklıdır. Verilen bilgiler için hiçbir sorumluluk kabul etmemekteyiz / حقوق التغيير محفوظة دون إشعار مسبق. دون أدنى مسؤولية عن المعلومات المقدمة

T	H	Diagrama de la Torre						T	H		
1	3,6		TL 3-90	TL 3-90	TL 3-90	TL 3-90	2,95	TL 3-90	158.32.000	1	3,6
2	6,5									2	6,5
3	9,5									3	9,5
4	12,4									4	12,4
5	15,4									5	15,4
6	18,3									6	18,3
7	21,3									7	21,3
8	24,2									8	24,2
9	27,2									9	27,2
10	30,1									10	30,1
11	33,1									11	33,1
12	36									12	36
13	39									13	39
14	41,9		T 3-90	T 3-90	T 3-90	T 3-90	2,95	T 3-90	133.32.000	14	41,9
15	44,9									15	44,9
16	47,8									16	47,8
17	50,8			T6-150A	161.31.300	T6-150A		T6-150A		17	53,7
18	53,7						5,82			18	59,5
19	59,5			T6-150	161.31.000	T6-150		T6-150		19	63,4
										20	69,0
										21	74,6
										22	80,2
										23	85,8

AN 90	133.21.000
AND 90	133.21.800
AN 150	161.21.000
AND 150	161.21.050
AL 20	153.21.800
ALD 20	160.21.250
AS 20	160.21.010
ASD 20/24	160.21.080
ASR 20	160.21.200
ASRD 20/24	156.21.000

T: Torre / Tower / Tour / Башни / Kuleler / أبراج
H: Altura / Height / Hauteur / Высота / Yükseklik / ارتفاع

Otras configuraciones de torre / Other tower configuration / Autres configurations / Прочие конфигурации / Diğer konfigürasyonlar / مكونات أخرى

Transporte
Transport / Transport /
Транспортировка / Taşıma / نقل

H=51,9 + BNI 45 100

6x

7x HIGH CUBE 40'

h_{max}: T6-90T + 13xTL3-90

h (m)	44,9
D (m)	10 - 20
P (KN)	579 519
Rmax (KN)	123 149

T6-90T = 139.32.700

Trepado interno / Internal climbing. / Téléscopage intérieur / Внутренняя лестница / Bina içi tırmanma / التسلق الداخلي

- ⚠ Viento fuera de servicio / Out of service wind / Vitesse du vent hors service / Ветровая нагрузка в покое / Rüzgar devre dışı / الريح خارج الخدمة
- 📄 Consultar / Consult / Nous consulter / Консультируйтесь / Danışınız / الرجوع إلى
- ▶ En servicio / In service / En service / В работе / Devrede / في الخدمة
- Fuera de servicio / Out of service / Hors service / В покое / Devre dışı / خارج الخدمة



Ctra./Rd. Madrid - Irún Km. 415 - 20.213 IDIAZABAL [Gipuzkoa] ESPAÑA / SPAIN
P.O. Box, 23 - 20.200 BEASAIN - E-mail: jaso@jaso.com
Tel. +34 943 - 18 70 00 • Fax. +34 943 - 18 70 20
www.jaso.com

Fecha / Date: 20/01/2016

FEM 1001

DELEGACION / DEALER

Reservado el derecho a modificaciones sin previo aviso. Declinamos toda responsabilidad derivada de la información proporcionada / Subject to modification, without previous warning. This information is supplied without liability / L'entreprise se réserve le droit de procéder à des modifications sans préavis. Nous déclinons toute responsabilité quant aux informations fournies / Мы оставляем за собой право на внесение изменений без предварительного уведомления. Мы снимаем с себя любую ответственность в отношении предоставленной информации / Önceden bildirilmeksizin değiştirilme hakkı saklıdır. Verilen bilgiler için hiçbir sorumluluk kabul etmemekteyiz /

حقوق التغيير محفوظة دون إشعار مسبق. دون أدنى مسؤولية عن المعلومات المقدمة